



LiteZilla

MANUAL

Installation Video:

www.LiteZilla.com/installationvideo

Digital Manual:

www.LiteZilla.com/litezilla-manual

PASSWORD readysetglow

Questions? 414-477-7772 / Adam@LiteZilla.com

TABLE OF CONTENTS

UNCRATING AND UNPACKING	1
Tools Needed	1
Unpacking Steps	1
PRE-INSTALLATION NOTES	2-5
Z-Clip Hanging Hardware	2
Wall Blocking	2
Power	2
Installation Template	3
Metal Support Legs	3
How High to Hang Your LiteZilla	4
How High to Place Your Electrical Outlet	5
SPECIALTY UNITS	6
INSTALLATION INSTRUCTIONS	7-4
Tools Needed	7
Materials Provided	8-9
Installation Steps 1-11	10-14
ACRYLIC LITEPINS INFORMATION	15
CLEANING AND SANITIZING	16
WARRANTY	17
TERMS AND CONDITIONS OF SALE	18-20
LIFETIME TECHNICAL SUPPORT	21

UNCRATING AND UNPACKING

TOOLS NEEDED

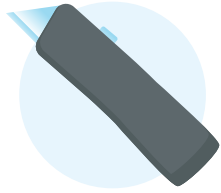

Utility Blade



Cutting Pliers



Drill with
Phillips Head

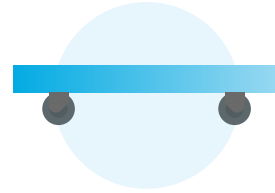

Moving Dolly



2 or More
Friends

Unpacking Steps

1 REMOVE THE PLASTIC WRAP

Use a utility blade to remove the protective plastic wrap from the crate. With a cutting pliers, cut any shipping straps that secure the boxes to the pallet.

2 REMOVE THE BOXES

The boxes contain your LitePins, LitePin sanitation basket, LitePin design LookBook, installation hardware, and metal support legs. Remove the boxes and put them aside.

3 FIND A FRIEND AND FURNITURE DOLLY

The LiteZilla is heavy. Find a friend and ready a moving dolly before you open the crate.

4 OPEN THE CRATE

One side of the crate says "Remove this side." Remove that side by unscrewing the screws on the **TOP AND EDGES**. With a friend or two, take the side off. You will see the LiteZilla has been placed in the crate face-first, so you will be looking at the back of the unit.

5 REMOVE THE LITEZILLA FROM THE CRATE

Carefully remove the LiteZilla and place it on your readied moving cart. With at least one person in front and one in the back, continue to hold the LiteZilla upright as you wheel the cart to the installation location. Once there, take the LiteZilla off the cart and place it on level ground that is free of debris.

PRE-INSTALLATION NOTES

Z-Clip Mounting System

The LiteZilla attaches to the wall with a piece of hardware called a Z-clip.

The Z-clip is two pieces of metal (one that stays on the LiteZilla and one that attaches to the wall) that fit together to secure the unit.

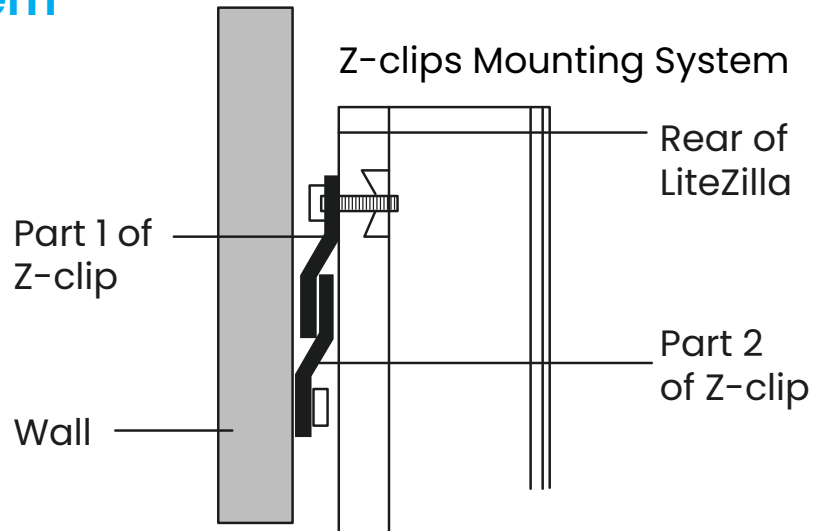

To prevent injury or damage, it is critical that the Z-clip that attaches to the wall (Part 2) is installed at the correct height. This will allow the 2 parts of the Z-clip to safely engage.

Therefore, the purpose of the mounting template is to show you where Part 2 needs to be located.

WALL BLOCKING

It is recommended that plywood wall blocking is installed behind the top half of all units to secure and support the Z-clip hardware.

POWER

A single cord comes out of the electrical cubby on the back of the unit and plugs into a standard 110V electrical outlet. International Orders will be built with power components to comply with local standards.

PRE-INSTALLATION NOTES

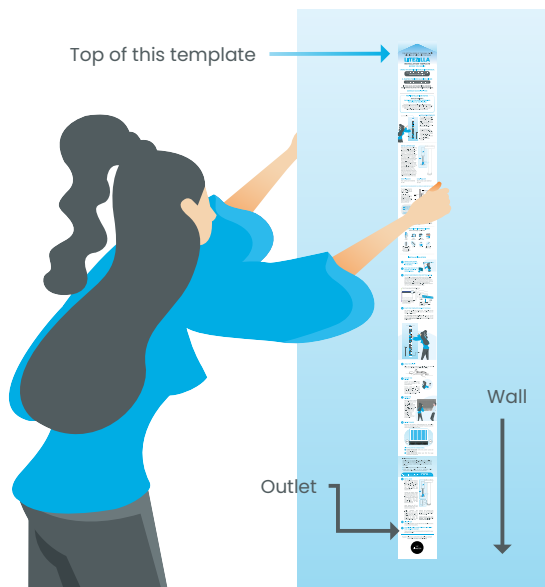

INSTALLATION TEMPLATE

The installation template is designed to show you where to place the wall Z-clip (Part 2). Place the hole in the bottom of the template over the electrical outlet that will power the LiteZilla.

The top edge of the installation template is now at the exact level of where the bottom edges of the Z-clip will be. Further detail is included in the Installation Instructions of this manual.

METAL SUPPORT LEGS

After the unit is securely hung on the metal Z-clip, metal legs are installed at the base of the frame for additional support. The white circular floor pad on the bottom of the legs can unscrew to provide an additional 3.5" of height. Notice the screw threads right above the floor pad are flat. The small wrench in the hardware box fits over those threads and should be used for the final adjustment of the threaded leveler to get the floor pad down to make contact with the floor. The feet are attached to the unit using the machine screws (in the hardware box) which are screwed into pre-threaded holes in the base of the unit.

Short legs are

6.5" and can extend to 10"

Long legs are

16.5" and can extend to 20"

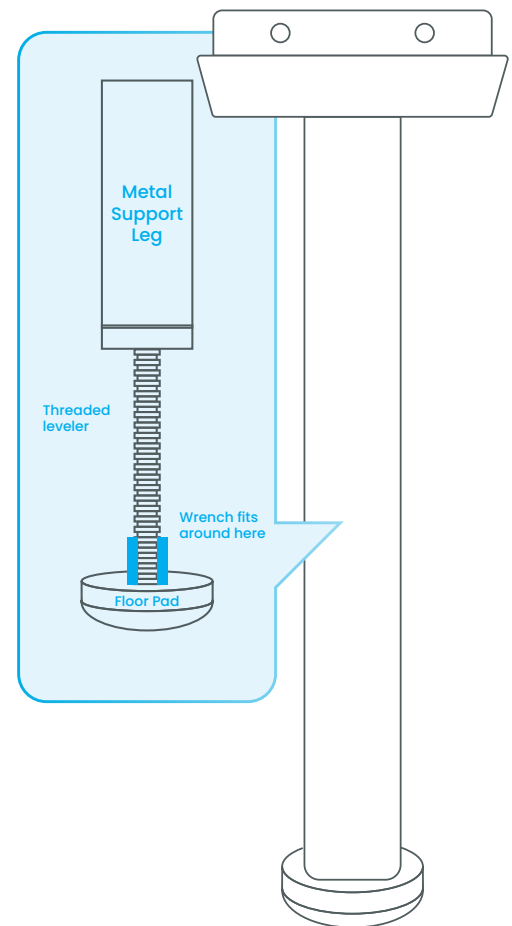

NEVER ATTACH THE LEGS BEFORE THE LITEZILLA IS HUNG ON THE Z-CLIP.

LITEZILLA HEIGHT

Several factors need to be considered when figuring out how high to hang your LiteZilla:

- ✓ Age and demographic of audience
- ✓ Length of the metal support legs
- ✓ Height of the electrical outlet

Each environment is different and the installation height is personal preference, but our recommendations are below:



Ages 0-4

Unit should be placed on the ground. No metal legs will be used.



Ages 4-10

Unit should be raised 6.5"-10" from the ground. Short legs will be used.

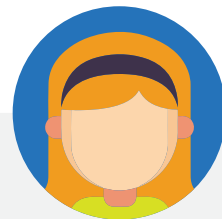

Ages 10+

Unit should be raised 16.5-20" from the ground. Long legs will be used.

NOTE: LiteZillas can be hung on the wall or placed on the floor and attached to the wall. Both installations require that Z-clips are used to secure it to the wall. The steps listed in the installation instructions should be followed the same way for either installation.

OUTLET HEIGHT

Note: The height of the electrical outlet determines the height at which the LiteZilla will hang. Therefore, to ensure the LiteZilla hangs at your desired height, you may need to raise or lower the electrical outlet accordingly.

From the back of the LiteZilla, you will see the power components located inside the electrical cubby. The unit is designed to be hung over the electrical outlet to safely hide the outlet and cords. To accomplish this, the electrical outlet needs to line up with this cubby so the center of the outlet is vertically centered with the power cubby.

Therefore, to ensure the LiteZilla hangs at your desired height, you may need to raise or lower the electrical outlet accordingly.

The table below will help determine the correct placement of the outlet.

LiteZilla Height	Distance from bottom of frame to middle of electrical cubby	Leg Length	Height of the center of a duplex outlet (the screw hole)	Height of installed unit (top edge)
32" and 46"	10"	no legs	16.5" - 20"	height of unit
5'	12"	no legs	18.5" - 22"	height of unit
6' and taller	14"	no legs	20.5 - 24"	height of unit
32" and 46"	10"	short	26.5" - 30"	height of unit + 6.5" - 10"
5'	12"	short	28.5" - 32"	height of unit + 6.5" - 10"
6' and taller	14"	Long	20.5 - 24"	height of unit + 6.5" - 10"
32" and 46"	10"	long	20.5 - 24"	height of unit + 16.5" - 20"
5'	12"	Long	26.5" - 30"	height of unit + 16.5" - 20"
6' and taller	14"	Long	28.5" - 32"	height of unit + 16.5" - 20"

SPECIALTY UNITS

Larger units may ship in (2) parts. These parts are assembled together once the Z-clips are placed on the wall.

Make your way through STEP 6 to attach the Z-clips to the wall. Install the (2) Z-clips about 4" from each other. **IT IS CRITICAL THAT THE Z-CLIPS ARE COMPLETELY LEVEL WITH ONE ANOTHER.**



ADDITIONAL HARDWARE

Specialty units have (2) additional set of screws (located in the hardware box). The longer screws are what will secure the top frame overhang and the smaller screws are what will secure the grid connector backing in place.

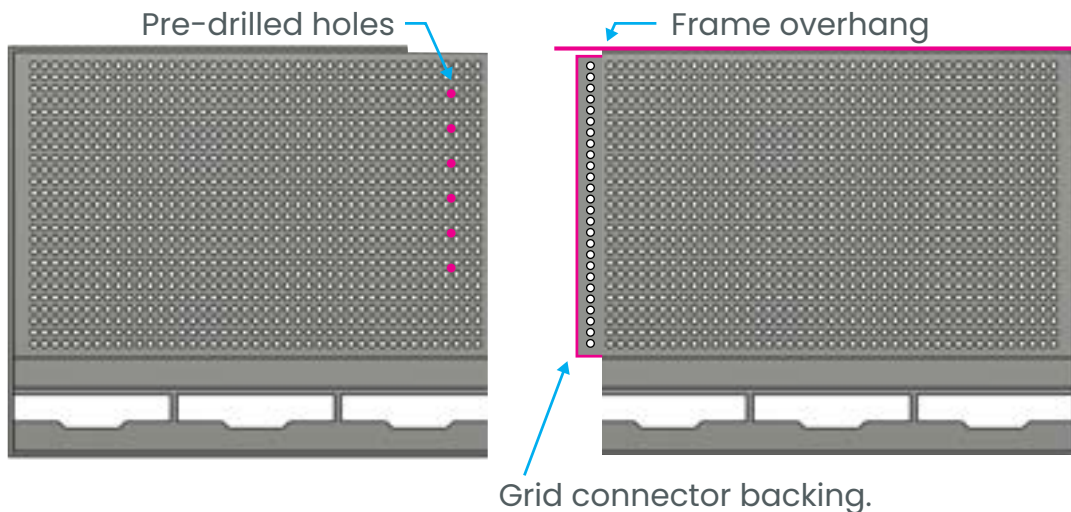

INSTALLING AND CONNECTING THE (2) HALVES

- 1 Hang the left half that has the missing top frame on the first. Then hang the right half and slide/maneuver it over so the overhanging piece of frame covers the missing section on the left half.
- 2 If the frosted acrylic behind the grid doesn't line up perfectly, gently maneuver the units and/or press on the acrylic so the (2) sides are seated nicely together. The (2) edges of the acrylic have been cut on an angle to minimize the seam.
- 3 Screw the top part of the frame (using the provided 2.5" drywall screws) into the left half to attach the 2 units together.
- 4 Now that the (2) parts are properly aligned and attached on the top, you will see the thin grid connector backing is behind the grid on the left half. There are pre-drilled holes in the left half that will drill into the grid to secure the (2) parts together. Use the provided **1 1/2" screws** through the grid to hold the smaller grid in place. ****Do not drill in and out more than needed. The screws are designed to go into the small grid piece one time to hold it together.**

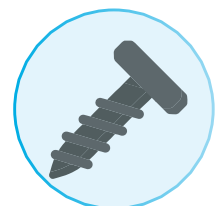

INSTALLATION INSTRUCTIONS

TOOLS NEEDED



Stud
finder



Tape
Measure



Drill with
phillips head

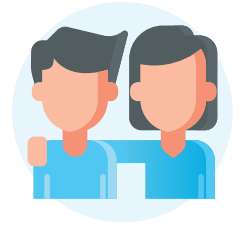

Friend



Drill bit for drilling
metal Z-clip (in case
new holes need to be
drilled to hit studs)



Level



Pencil



Electrical
Outlet Tester

INSTALLATION INSTRUCTIONS

MATERIALS PROVIDED

THE BOTTOM EDGE OF THE WALL Z-CLIP WILL LINE UP WITH THIS TOP EDGE.

LITEZILLA
INSTALLATION TEMPLATE
DETAILED INSTRUCTIONS
www.dretille.com/litezilla-miscual
#myzillagrow

INSTALLATION NOTE

FINISHED HEIGHT:
For the best Z-clip connection to facilitate the final height, please ensure the Z-clip is properly aligned with the LiteZilla. The Z-clip should be placed on the wall at the height of the LiteZilla. The Z-clip should be placed on the wall at the height of the LiteZilla. The Z-clip should be placed on the wall at the height of the LiteZilla.

Before you begin, you'll need:

- 2.5" Drywall Screws
- Wall Z-clip
- Unit Z-clip
- Level
- Utility Knife
- Scissors
- Measuring Tape
- Drill
- Marker
- Power Drill
- Phillips Screwdriver
- Flathead Screwdriver
- Wrench
- Adjustable Wrench
- Hex Key
- Hex Key Bit
- Hex Key Bit Adapter
- Hex Key Bit Holder
- Hex Key Bit Storage Case
- Hex Key Bit Cleaning Cloth
- Hex Key Bit Lubricant
- Hex Key Bit Storage Bag
- Hex Key Bit Storage Box
- Hex Key Bit Storage Container
- Hex Key Bit Storage Tray
- Hex Key Bit Storage Pad
- Hex Key Bit Storage Mat
- Hex Key Bit Storage Sheet
- Hex Key Bit Storage Roll
- Hex Key Bit Storage Tube
- Hex Key Bit Storage Canister
- Hex Key Bit Storage Jar
- Hex Key Bit Storage Bucket
- Hex Key Bit Storage Bin
- Hex Key Bit Storage Basket
- Hex Key Bit Storage Bag
- Hex Key Bit Storage Box
- Hex Key Bit Storage Container
- Hex Key Bit Storage Tray
- Hex Key Bit Storage Pad
- Hex Key Bit Storage Mat
- Hex Key Bit Storage Sheet
- Hex Key Bit Storage Roll
- Hex Key Bit Storage Tube
- Hex Key Bit Storage Canister
- Hex Key Bit Storage Jar
- Hex Key Bit Storage Bucket
- Hex Key Bit Storage Bin
- Hex Key Bit Storage Basket

STEP 1
LOCATE THE Z-CLIP ON THE WALL

STEP 2
LOCATE THE Z-CLIP ON THE WALL

STEP 3
LOCATE THE Z-CLIP ON THE WALL

STEP 4
LOCATE THE Z-CLIP ON THE WALL

STEP 5
LOCATE THE Z-CLIP ON THE WALL

STEP 6
LOCATE THE Z-CLIP ON THE WALL

STEP 7
LOCATE THE Z-CLIP ON THE WALL

STEP 8
LOCATE THE Z-CLIP ON THE WALL

STEP 9
LOCATE THE Z-CLIP ON THE WALL

STEP 10
LOCATE THE Z-CLIP ON THE WALL

Installation Template - (located on the back of the LiteZilla under the Z-clip for the unit)

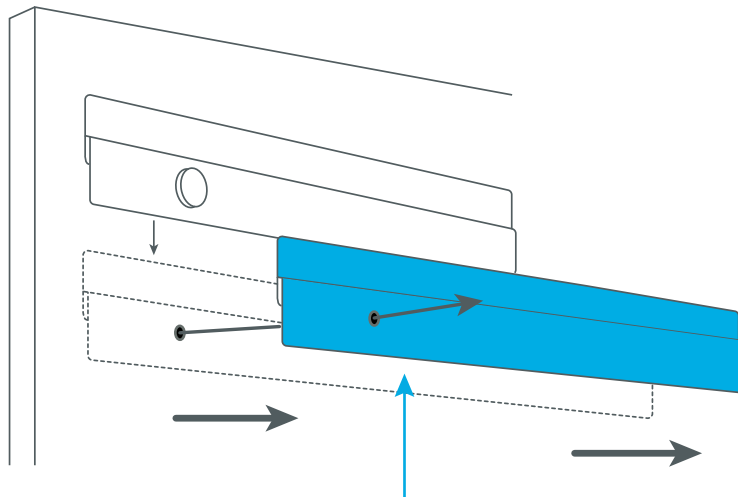

Z-clip for Wall - (located on the back of the LiteZilla under the Z-clip for the unit)

2.5" Drywall Screws - To install the Z-clip to the wall (located in the hardware box)



INSTALLATION INSTRUCTIONS

MATERIALS PROVIDED CONTINUED...

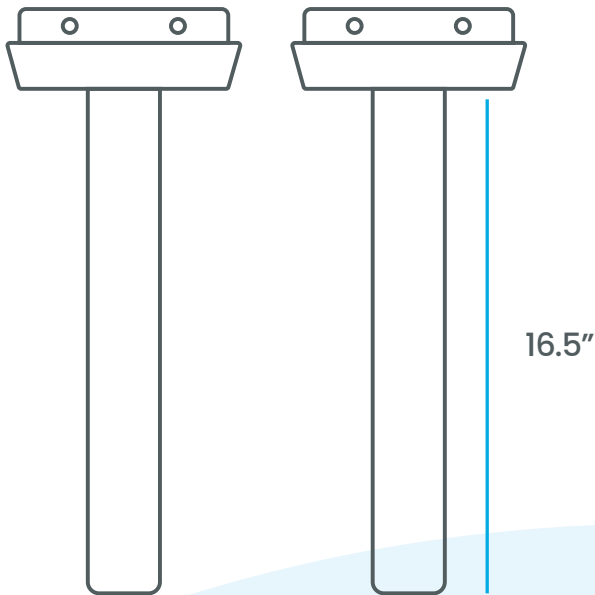

(2) Pairs of Metal Support Legs -
(only 1 pair will be used)

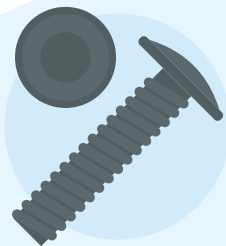
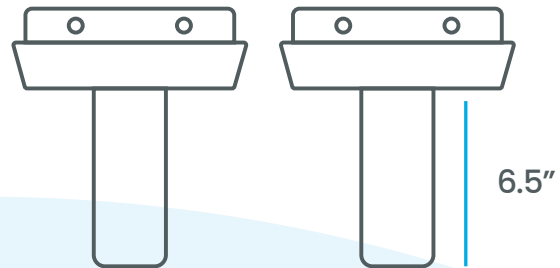

(8) 1/2" Button Head
Cap Screws - To install
the support legs to the
unit (located in the
hardware box)



Wrench for final
adjustment of Threaded
Levelers - (located in
the hardware box)

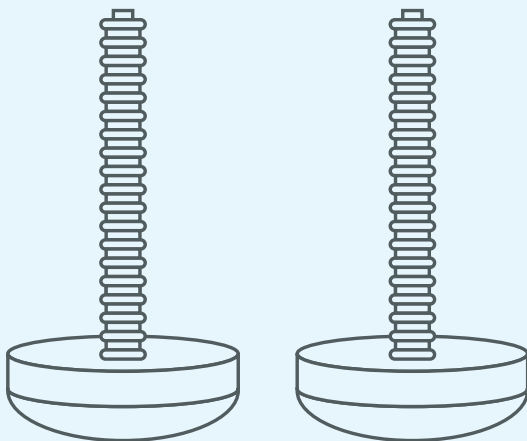

(1) pair of Threaded Levelers -
to be screwed into the pair
of Support Legs you will use.

INSTALLATION STEPS

1 LOCATE THE STUDS OR WOOD BACKING IN THE WALL



2 TEST THE OUTLET TO ENSURE THAT IT IS OPERATIONAL



3 LOCATE AND REMOVE THE BOTTOM Z-CLIP

The LiteZilla is shipped with both parts of the Z-clip attached to the back of the unit. The top piece is permanent and should not be removed. The bottom part (Part 2) is held on by temporary screws. Remove these screws and discard them. The screws for attaching the Z-clip to the wall are located in the box with your hardware and support legs.

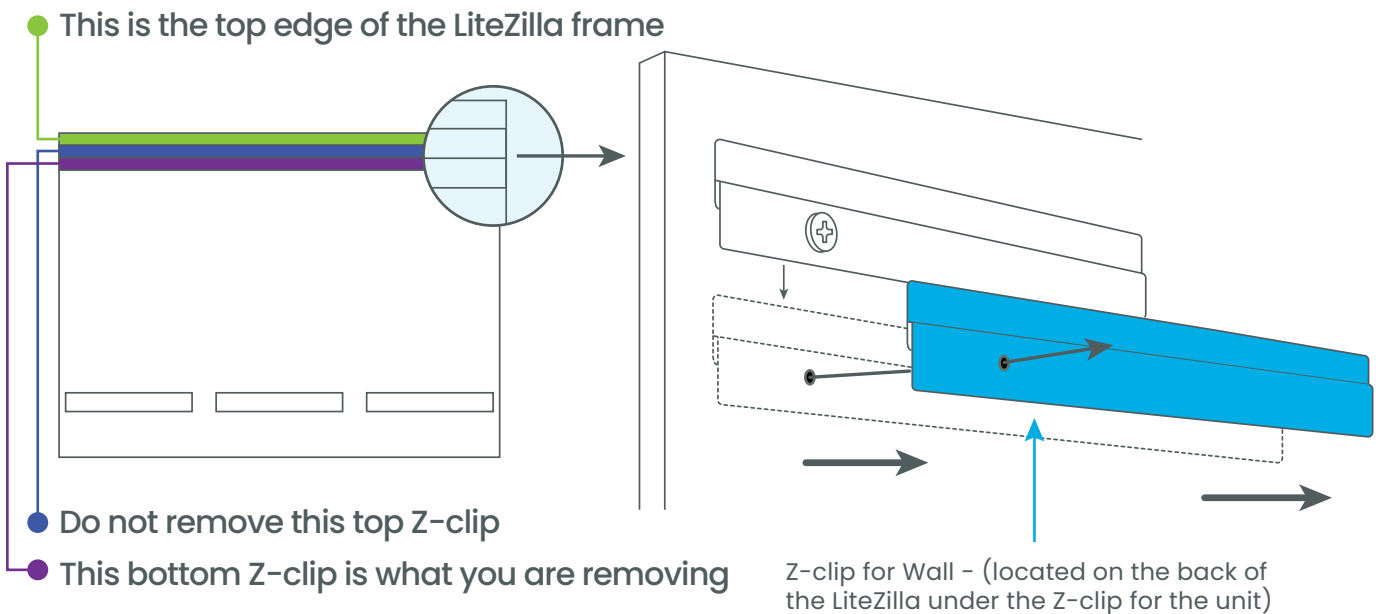

INSTALLATION STEPS CONTINUED...

4 PLACE THE TEMPLATE AGAINST THE WALL

The arrow should be facing up. The hole at the bottom should be directly over the outlet that the LiteZilla will plug into.

The **top edge of the template** will now be at the correct height to properly mark the location of the **bottom edge of the wall Z-clip**. Use a pencil to mark this location.

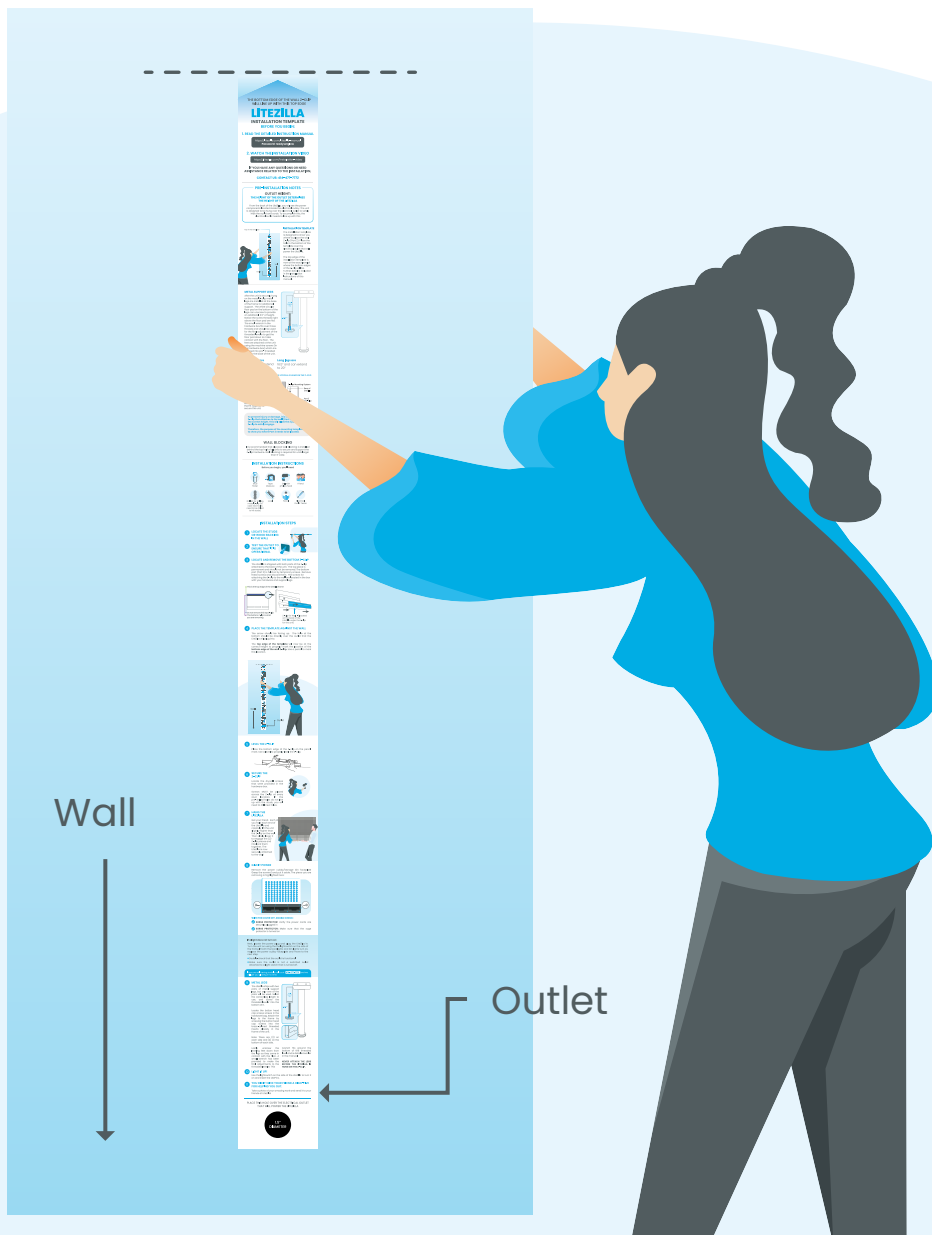

INSTALLATION STEPS CONTINUED...

5 LEVEL THE Z-CLIP

Place the bottom edge of the Z-clip on the pencil mark. Use a level to properly level the Z-clip.

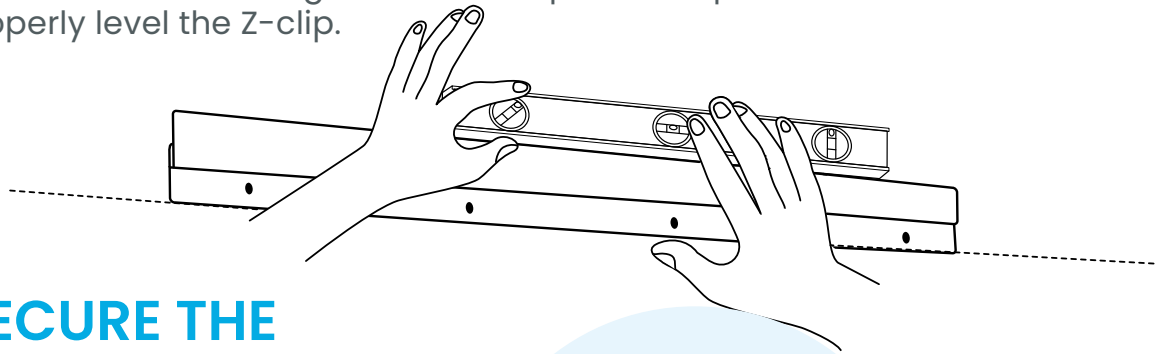

6 SECURE THE Z-CLIP

Locate the drywall screws that were provided in the hardware box.

Screws MUST be placed across the Z-clip at every stud location. If the pre-drilled holes do not line up with the studs, you will need to drill new holes.



7 HANG THE LITEZILLA

Get your friend. Each of you hold each end of the LiteZilla and carefully lift the unit slightly higher than the Z-clip on the wall. Then slowly lower it to engage the (2) Z-clip pieces and interlock them together. The LiteZilla is now securely attached to the wall!



INSTALLATION STEPS CONTINUED...

8

GIVE IT POWER

Remove the power cubby/storage bin faceplate (keep the screws) and put it aside. The piece you are removing is highlighted here:

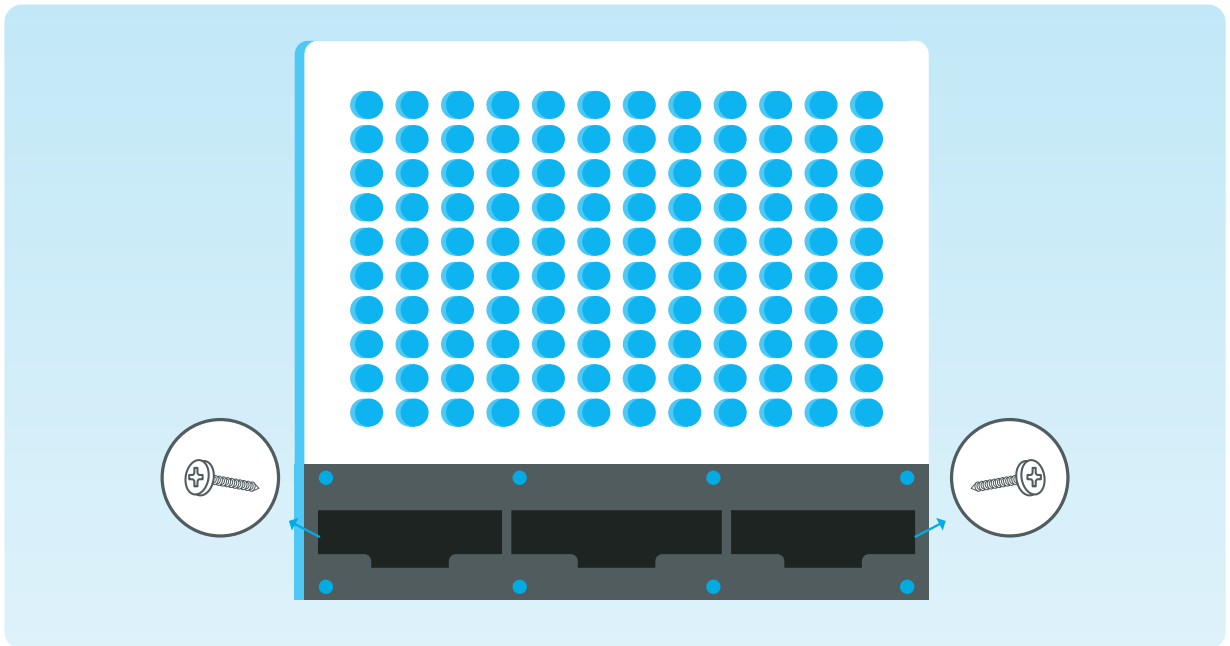

WITH THE COVER OFF, DOUBLE CHECK:

- ✓ **SURGE PROTECTOR:** Verify the power cords are securely plugged in
- ✓ **SURGE PROTECTOR:** Make sure that the surge protector is turned on

Next, locate the power plug and plug the LiteZilla in. Turn the unit on using the the lightswitch on the side of the frame. If both the backlights and bin lights turn on, replace the power cubby faceplate and move to the next step.

If a light does not turn on:

- ✓ Double-check that the outlet is functional
- ✓ Make sure the outlet is not a switched outlet attached to a light switch that is turned off.

If you are still having trouble, call us at **414-477-7772** and we will get you glowing in no time.

INSTALLATION STEPS CONTINUED...

9 METAL LEGS

The LiteZilla ships with two pairs of metal support legs, but only one of the pairs will be used. Select the correct leg length to use, and screw the threaded leveler into the bottom of it.

Locate the button head cap screws screws in the hardware bag. Attach the legs to the frame by screwing the button head cap screws into the brass-colored threaded inserts already in the frame of the unit.

Note: There are (2) on each side and (2) on the bottom of each side.

Lastly, unscrew the leveling feet down from the legs so they come in contact with the floor. A small wrench has been provided to make the final adjustments to the threaded leveler. This wrench fits ground the bottom of the threaded level and is detailed earlier in the manual.

NEVER ATTACH THE LEGS BEFORE THE LITEZILLA IS HUNG ON THE Z-CLIP.

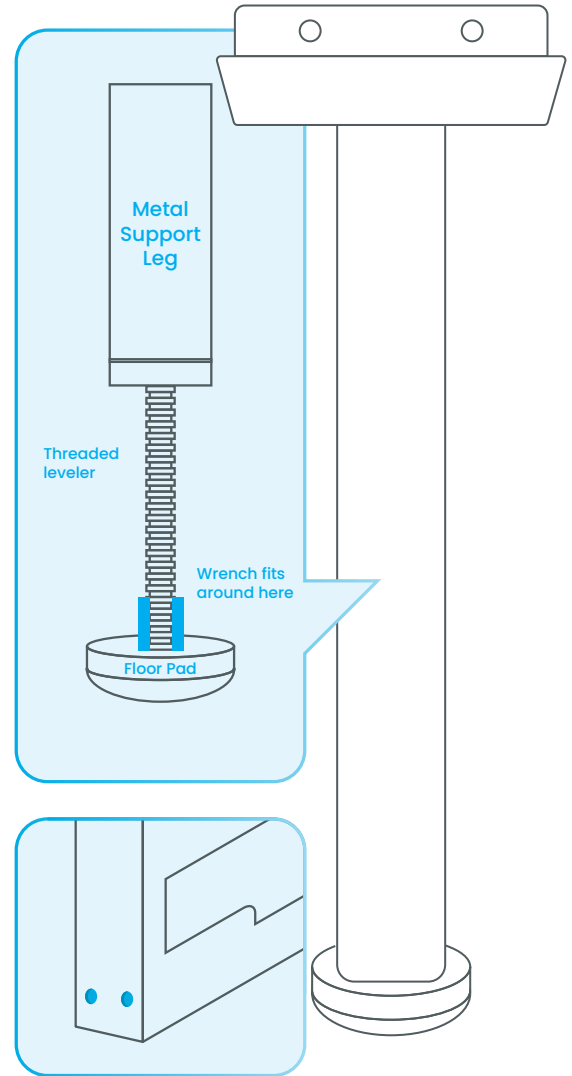

10 LIGHT IT UP!

Use the lightswitch on the side of the LiteZilla to turn it on and insert the LitePins.

11 YOU DID IT! GIVE YOUR FRIEND A HIGH-FIVE FOR HELPING YOU OUT.

Take a photo of your amazing work and send it to your friends at LiteZilla!

ACRYLIC LITEPINS INFORMATION

Standard LitePins

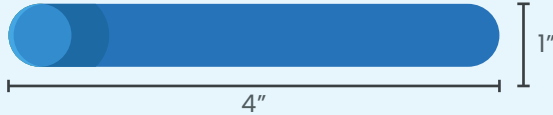

Mini LitePins



ABOUT THE LITEPINS

- ✓ After each Pin is cut to length, our finishing process ensures that each Pin is polished to ensure a smooth end with no sharp edges.
- ✓ LitePins are not affected by sunlight, moisture, or heat.

LITEPINS CARE

LitePins should be used over a soft surface. If LitePins are dropped over a hard surface (like tile or stone), over time, the edges of the ends will feel coarse and will develop small chips in them. If the flooring is hard, we recommend that a runner or soft mat is placed below the LiteZilla.

LITEPINS SAFETY

- ✓ Our standard length LitePins have been cleared by a licensed pediatrician as non-choking hazards. Additionally, they have been tested using the Consumer Product Safety Commission's (CPSC), Small Objects Tester and pass all requirements for choking safety.

To avoid injuries and maintain a safe environment, the LitePins should not be used in any other way other than their intended purpose.

We have spent years testing and working directly with some of the best acrylic manufacturers in the world.

We carefully oversee each step of the cutting and polishing process to ensure our customers receive the highest-quality acrylic and most beautiful color selections.

Even so, it is possible that you may find a LitePin that is too large to fit in a grid hole or a few that have some color variations. These occurrences are normal with acrylic rods, and the LiteZilla team has provided you a few extras to accommodate

CLEANING AND SANITIZING

LITEZILLA

FOR LIGHT CLEANING:

Use any non-abrasive all-purpose cleaner or disinfectant wipe and dry with a paper towel or microfiber cloth

*Canned air is also an effective means of clearing your grid, vents, and cubbies of dust. Be sure the can is upright before spraying.

FOR DEEPER SANITATION:

Use a Medical grade disinfectant wipe and clean the front grid, frame, and LitePin bins

LITEPINS

The most effective way to clean the LitePins is by placing them in a dishwasher in our LitePin Sanitation Basket. If you do not have one and would like to order one, please go to:

<https://litezilla.com/shop/sanitation-basket/>

To use the Sanitation Basket:

- 1 Clear the dishwasher bottom rack and remove silverware holder.
- 2 Place the empty sanitation basket on bottom rack-allowing the rack prongs to go through the bottom holes of the basket to hold it in place. The basket should be nestled securely without bending any of the prongs.
- 3 Collect your LitePins and distribute them evenly in the Sanitation Basket. For optimal results, do not exceed 220 LitePins per load.
- 4 Place your desired dishwashing detergent into your washer and run a cycle on high heat with heat drying.
- 5 While you wait, use a disinfecting wipe to clean your LiteZilla unit, grid holes, and cubbies.
- 6 When the dishwashing cycle is complete, remove your sparkling clean LitePins from the basket.

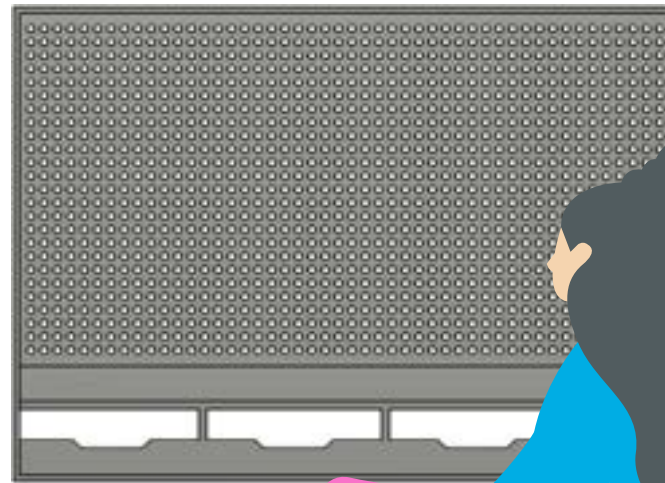

If you do not have a Sanitation Basket, prepare a solution of dish soap, water, and bleach. Soak the LitePins in the solution. Use a rag to wipe them down. Remove and place them on a clean towel to dry.

WARRANTY

LIMITED WARRANTY.

THIS LIMITED WARRANTY GIVES YOU SPECIFIC LEGAL RIGHTS AND YOU MAY ALSO HAVE OTHER RIGHTS, WHICH VARY FROM STATE TO STATE. THIS LIMITED WARRANTY CAN ALSO BE FOUND AT WWW.LITEZILLA.COM/WARRANTY AND IN THE DOCUMENTATION WE PROVIDE WITH THE PRODUCTS.

WE WARRANT THAT DURING THE WARRANTY PERIOD, THE PRODUCTS PURCHASED FROM LITEZILLA WILL BE FREE FROM DEFECTS IN MATERIALS AND WORKMANSHIP.

WE LIMIT THE DURATION AND REMEDIES OF ALL IMPLIED WARRANTIES, INCLUDING WITHOUT LIMITATION THE WARRANTIES OF MERCHANTABILITY AND FITNESS FOR A PARTICULAR PURPOSE, TO THE DURATION OF THIS LIMITED WARRANTY.

SOME STATES DO NOT ALLOW LIMITATIONS ON HOW LONG AN IMPLIED WARRANTY LASTS, SO THE ABOVE LIMITATION MAY NOT APPLY TO YOU. OUR RESPONSIBILITY FOR DEFECTIVE PRODUCTS IS LIMITED TO REPAIR, REPLACEMENT OR REFUND AS SET FORTH IN THIS WARRANTY STATEMENT. OUR RESPONSIBILITY FOR DEFECTIVE SERVICES IS LIMITED TO REPAIR, RE-PERFORMANCE OR REFUND AS SET FORTH IN THIS WARRANTY STATEMENT. NEITHER ANY PERFORMANCE OR OTHER CONDUCT, NOR ANY ORAL OR WRITTEN INFORMATION, STATEMENT OR ADVICE PROVIDED BY US OR ANY OF OUR SUPPLIERS, AGENTS OR EMPLOYEES WILL CREATE A WARRANTY, OR IN ANY WAY INCREASE THE SCOPE OR DURATION OF THIS LIMITED WARRANTY.

a WHO MAY USE THIS WARRANTY?

This limited warranty extends only to the original purchaser of products and services from LiteZilla. It does not extend to any subsequent or other owner or transferee of the product or any transferee or other beneficiary of the service.

b WHAT DOES THIS WARRANTY COVER?

This limited warranty covers during the Warranty Period (as defined below) defects in materials and workmanship in products purchased from LiteZilla.

c WHAT DOES THIS WARRANTY NOT COVER?

This limited warranty does not cover any damages due to:

(i) transportation; (ii) storage; (iii) improper use; (iv) failure to follow the product instructions or to perform any preventive maintenance; (v) modifications; (vi) combination or use with any products, materials, processes, systems or other matter not provided or authorized in writing by LiteZilla; (vii) unauthorized repair; (viii) normal wear and tear; or (ix) external causes such as accidents, abuse, or other actions or events beyond our reasonable control.

d WHAT IS THE PERIOD OF COVERAGE ?

This limited warranty lasts for two (2) years (the "Warranty Period") as of the Shipping Date. The Warranty Period is not extended if we repair or replace a warranted product or re-perform a warranted service. We may change the availability of this limited warranty at our discretion, but any changes will not be retroactive.

e WHAT ARE YOUR REMEDIES UNDER THIS WARRANTY ?

With respect to any defective products during the Warranty Period, we will, in our sole discretion, either: (i) repair or replace such products (or the defective part) free of charge or (ii) refund the purchase price of such products. We will also pay for shipping and handling fees to return the repaired or replacement product to you if we elect to repair or replace the defective products.

f HOW DO YOU OBTAIN WARRANTY SERVICE ?

With respect to any defective products during the Warranty Period, we will, in our sole discretion, either: (i) repair or replace such products (or the defective part) free of charge or (ii) refund the purchase price of such products. We will also pay for shipping and handling fees to return the repaired or replacement product to you if we elect to repair or replace the defective products.

LITEZILLA, LLC TERMS AND CONDITIONS FOR THE SALE OF GOODS

1. APPLICABILITY.

- a These terms and conditions of sale (these “Terms”) are the only terms which govern the sale of the goods (“Goods”) by LiteZilla LLC (“Seller” or “LiteZilla”) to the buyer named on the reverse side of these Terms or in the accompanying Sales Confirmation (“Buyer” or “you”). Notwithstanding anything here in to the contrary, if a written contract signed by both parties is in existence covering the sale of the Goods covered hereby, the terms and conditions of said contract shall prevail to the extent they are inconsistent with these Terms.
- b The accompanying quotation, proposal and/or invoice (the “Sales Confirmation” and these Terms (collectively, this “Agreement”), comprise the entire agreement between the parties, and supersede all prior or contemporaneous understandings, agreements, negotiations, representations and warranties, and communications, both written and oral. These Terms prevail over any of Buyer’s general terms and conditions of purchase regardless whether or when Buyer has submitted its purchase order or such terms. Fulfillment of Buyer’s order does not constitute acceptance of any of Buyer’s terms and conditions and does not serve to modify or amend these Terms.

2. SHIPMENTS; DELIVERY; TITLE AND RISK OF LOSS.

- a We will arrange for shipment of the products to you. Please check the Sales Confirmation for specific delivery options. Delivery shall be made FOB Origin [4997B North 33rd street, Milwaukee WI 53209]. You will pay all shipping and handling charges specified during the ordering process.
- b Title and risk of loss pass to you upon our transfer of the products to the carrier. Shipping and delivery dates are estimates only and cannot be guaranteed. We are not liable for any delays in shipments or damage incurred during shipment.

3. RETURNS AND REFUNDS.

LiteZilla products are non-refundable, notwithstanding Section 5 (Inspection and Rejection of Nonconforming Goods) below. You are permitted to amend or alter your Sales Confirmation within fourteen (14) days following your acceptance of the Sales Confirmation. Any proposed amendment or alteration must be submitted in writing via email to info@litezilla.com.

4. AMENDMENT AND MODIFICATION.

These Terms may only be amended or modified in a writing which specifically states that it amends these Terms and is signed by an authorized representative of each party.

5. INSPECTION AND REJECTION OF NONCONFORMING GOODS.

- a Buyer shall inspect the Goods within five (5) days of receipt (“Inspection Period”). Buyer will be deemed to have accepted the Goods unless it notifies Seller in writing of any Nonconforming Goods during the Inspection Period and furnishes such written evidence or other documentation as reasonably required by Seller. “Nonconforming Goods” means only the following: (i) product shipped is different than identified in Buyer’s purchase order; or (ii) product’s label or packaging incorrectly identifies its contents.
- b If Buyer timely notifies Seller of any Nonconforming Goods, Seller shall, in its sole discretion, (i) replace such Nonconforming Goods with conforming Goods, or (ii) credit or refund the Price for such Nonconforming Goods, together with any reasonable shipping and handling expenses incurred by Buyer in connection therewith. Buyer shall ship, at its expense and risk of loss, the Nonconforming Goods to Seller’s facility located in Cedarburg, WI. If Seller exercises its option to replace Nonconforming Goods, Seller shall, after receiving Buyer’s shipment of Nonconforming Goods, ship to Buyer, at Buyer’s expense and risk of loss, the replaced Goods.
- c Buyer shall not withhold payment of any amounts due and payable by reason of any set-off of any claim or dispute with Seller, whether relating to Seller’s breach, bankruptcy or otherwise.

6. PRICE.

- a Buyer shall purchase the Goods from Seller at the price(s) (the “Price(s)”) set forth in the accompanying Sales Confirmation.
- b All Prices are exclusive of all sales, use and excise taxes, and any other similar taxes, duties and charges of any kind imposed by any Governmental Authority on any amounts payable by Buyer. Buyer shall be responsible for all such charges, costs and taxes; provided, that, Buyer shall not be responsible for any taxes imposed on, or with respect to, Seller’s income, revenues, gross receipts, personnel or real or personal property or other assets

7. PAYMENT TERMS.

- a Buyer shall pay the Price in accordance with the noted and agreed upon payment terms located in the Sales Confirmation. Buyer shall make all payments hereunder in accordance with the Sales Confirmation.

- b** Buyer shall pay interest on all late payments at the lesser of the rate of 1.5% per month or the highest rate permissible under applicable law, calculated daily and compounded monthly. Buyer shall reimburse Seller for all costs incurred in collecting any late payments, including, without limitation, attorneys' fees. In addition to all other remedies available under these Terms or at law (which Seller does not waive by the exercise of any rights here under), Seller shall be entitled to suspend the delivery of any Goods if Buyer fails to pay any amounts when due hereunder and such failure continues for fifteen (15) days following written notice there of.
- c** Buyer shall not withhold payment of any amounts due and payable by reason of any set-off of any claim or dispute with Seller, whether relating to Seller's breach, bankruptcy or otherwise.

8. LIMITATION OF LIABILITY.

IN NO EVENT SHALL SELLER BE LIABLE TO BUYER OR ANY THIRD PARTY FOR ANY LOSS OF USE, REVENUE OR PROFIT OR LOSS OF DATA OR DIMINUTION IN VALUE, OR FOR ANY CONSEQUENTIAL, INDIRECT, INCIDENTAL, SPECIAL, EXEMPLARY, OR PUNITIVE DAMAGES WHETHER ARISING OUT OF BREACH OF CONTRACT, TORT (INCLUDING NEGLIGENCE) OR OTHERWISE, REGARDLESS OF WHETHER SUCH DAMAGES WERE FORESEEABLE AND WHETHER OR NOT SELLER HAS BEEN ADVISED OF THE POSSIBILITY OF SUCH DAMAGES, AND NOTWITHSTANDING THE FAILURE OF ANY AGREED OR OTHER REMEDY OF ITS ESSENTIAL PURPOSE. (b) IN NO EVENT SHALL SELLER'S AGGREGATE LIABILITY ARISING OUT OF OR RELATED TO THIS AGREEMENT, WHETHER ARISING OUT OF OR RELATED TO BREACH OF CONTRACT, TORT (INCLUDING NEGLIGENCE) OR OTHERWISE, EXCEED THE TOTAL OF THE AMOUNTS PAID TO SELLER FOR THE GOODS SOLD HEREUNDER.

9. INDEMNIFICATION.

- a** Buyer covenants and agrees that it shall defend, indemnify and hold Seller and all of its officers, agents and employees (each a "Seller Indemnitee") harmless for any claim, loss, damage, cost, charge, expense, lien, settlement or judgment, including interest thereon, including employees of Buyer, or property or both, arising out of or in connection with Buyer's performance of the Agreement or in connection with the use of the Goods, to which Seller or any of its officers, agents or employees may be subject or put by reason of any act or omission on the part of Buyer, or any of its officers, agents and employees. Buyer shall not be liable under this section for damage to persons or property directly caused or resulting from the sole negligence of Seller, or any of its officers, agents or employees.
- b** In the event any suit or other proceedings for any claim, loss, damage, cost, charge or expense covered by Buyer's foregoing indemnity should be brought against any Seller Indemnitee, Buyer hereby covenants and agrees to assume the defense thereof and defend the same at Buyer's own expense and to pay any and all costs, charges, attorney's fees, and other expenses, and any and all judgments that may be incurred by or obtained against any Seller Indemnitee in such suits or other proceedings. In the event of any judgment or other lien being placed upon the property of Seller in such suits or other proceedings, Buyer shall at once cause the same to be dissolved and discharged by giving bond or otherwise.

10. COMPLIANCE WITH LAW.

Buyer shall comply with all applicable laws, regulations and ordinances. Buyer shall maintain in effect all the licenses, permissions, authorizations, consents and permits that it needs to carry out its obligations under this Agreement. Buyer shall comply with all export and import laws of all countries involved in the sale of the Goods under this Agreement or any resale of the Goods by Buyer. Buyer assumes all responsibility for shipments of Goods requiring any government import clearance. Seller may terminate this Agreement if any governmental authority imposes antidumping or countervailing duties or any other penalties on Goods.

11. TERMINATION.

In addition to any remedies that may be provided under these Terms, Seller may terminate this Agreement with immediate effect upon written notice to Buyer, if Buyer: (i) fails to pay any amount when due under this Agreement; (ii) has not otherwise performed or complied with any of these Terms, in whole or in part; or (iii) becomes insolvent, files a petition for bankruptcy or commences or has commenced against it proceedings relating to bankruptcy, receivership, reorganization or assignment for the benefit of creditors. Seller may also terminate this Agreement for any reason by providing Buyer with thirty (30) days' written notice of its desire to terminate the Agreement.

12. CONFIDENTIAL INFORMATION.

All non-public, confidential or proprietary information of Seller, including but not limited to specifications, samples, patterns, designs, plans, drawings, documents, data, business operations, customer lists, pricing, discounts or rebates, disclosed by Seller to Buyer, whether disclosed orally or disclosed or accessed in written, electronic or other form or media, and whether or not marked, designated or otherwise identified as "confidential" in connection with this Agreement is confidential, solely for the use of performing this Agreement and may not be disclosed or copied unless authorized in advance by Seller in writing. Upon Seller's request, Buyer shall promptly return all documents and other materials received from Seller. Seller shall be entitled to injunctive relief for any violation of this Section. This Section does not apply to information that is: (a) in the public domain; (b) known to Buyer at the time of disclosure; or (c) rightfully obtained by Buyer on a non-confidential basis from a third party.

13. WAIVER.

No waiver by Seller of any of the provisions of this Agreement is effective unless explicitly set forth in writing and signed by Seller. No failure to exercise, or delay in exercising, any right, remedy, power or privilege arising from this Agreement operates, or may be construed, as a waiver thereof. No single or partial exercise of any right, remedy, power or privilege hereunder precludes any other or further exercise thereof or the exercise of any other right, remedy, power or privilege.

14. FORCE MAJEURE.

The Seller shall not be liable or responsible to Buyer, nor be deemed to have defaulted or breached this Agreement, for any failure or delay in fulfilling or performing any term of this Agreement when and to the extent such failure or delay is caused by or results from acts or circumstances beyond the reasonable control of Seller including, without limitation, acts of God, flood, fire, earthquake, explosion, governmental actions, war, invasion or hostilities (whether war is declared or not), terrorist threats or acts, riot, or other civil unrest, national emergency, revolution, insurrection, epidemic, lockouts, strikes or other labor disputes (whether or not relating to either party's workforce), or restraints or delays affecting carriers or inability or delay in obtaining supplies of adequate or suitable materials, materials or telecommunication breakdown or power outage.

15. ASSIGNMENT.

Buyer shall not assign any of its rights or delegate any of its obligations under this Agreement without the prior written consent of Seller. Any purported assignment or delegation in violation of this Section is null and void. No assignment or delegation relieves Buyer of any of its obligations under this Agreement.

16. RELATIONSHIP OF THE PARTIES.

The relationship between the parties is that of independent contractors. Nothing contained in this Agreement shall be construed as creating any agency, partnership, joint venture or other form of joint enterprise, employment or fiduciary relationship between the parties, and neither party shall have authority to contract for or bind the other party in any manner whatsoever.

17. NO THIRD-PARTY BENEFICIARIES.

This Agreement is for the sole benefit of the parties hereto and their respective successors and permitted assigns and nothing herein, express or implied, is intended to or shall confer upon any other person or entity any legal or equitable right, benefit or remedy of any nature whatsoever under or by reason of these Terms.

18. GOVERNING LAW AND JURISDICTION.

All matters arising out of or relating to these Terms are governed by and construed in accordance with the internal laws of the State of Wisconsin without giving effect to any choice or conflict of law provision or rule (whether of the State of Wisconsin or any other jurisdiction) that would cause the application of the laws of any jurisdiction other than those of the State of Wisconsin.

19. DISPUTE RESOLUTION.

- a YOU AND LITEZILLA ARE AGREEING TO GIVE UP ANY RIGHTS TO LITIGATE CLAIMS IN A COURT OR BEFORE A JURY, OR TO PARTICIPATE IN A CLASS ACTION OR REPRESENTATIVE ACTION WITH RESPECT TO A CLAIM. OTHER RIGHTS THAT YOU WOULD HAVE IF YOU WENT TO COURT MAY ALSO BE UNAVAILABLE OR MAY BE LIMITED IN ARBITRATION. ANY CLAIM, DISPUTE OR CONTROVERSY (WHETHER IN CONTRACT, TORT OR OTHERWISE, WHETHER PRE-EXISTING, PRESENT OR FUTURE, AND INCLUDING STATUTORY, CONSUMER PROTECTION, COMMON LAW, INTENTIONAL TORT, INJUNCTIVE AND EQUITABLE CLAIMS) BETWEEN YOU AND US ARISING FROM OR RELATING IN ANY WAY TO YOUR PURCHASE OF PRODUCTS OR SERVICES THROUGH THE SITE, WILL BE RESOLVED EXCLUSIVELY AND FINALLY BY BINDING ARBITRATION
- b The arbitration will be administered by the American Arbitration Association (“AAA”) in accordance with the Consumer Arbitration Rules (the “AAA Rules”) then in effect, except as modified by this Section 20. (The AAA Rules are available at www.adr.org/arb_med or by calling the AAA at 1-800-778- 7879.) The Federal Arbitration Act will govern the interpretation and enforcement of this section. The arbitrator will have exclusive authority to resolve any dispute relating to arbitrability and/or enforceability of this arbitration provision, including any unconscionability challenge or any other challenge that the arbitration provision or the Agreement is void, voidable or otherwise invalid. The arbitrator will be empowered to grant whatever relief would be available in court under law or in equity. Any award of the arbitrator(s) will be final and binding on each of the parties and may be entered as a judgment in any court of competent jurisdiction.
- c You agree to an arbitration on an individual basis. In any dispute, NEITHER YOU NOR LITEZILLA WILL BE ENTITLED TO JOIN OR CONSOLIDATE CLAIMS BY OR AGAINST OTHER CUSTOMERS IN COURT OR IN ARBITRATION OR OTHERWISE PARTICIPATE IN ANY CLAIM AS A CLASS REPRESENTATIVE, CLASS MEMBER OR IN A PRIVATE ATTORNEY GENERAL CAPACITY. The arbitral tribunal may not consolidate more than one person’s claims, and may not otherwise preside over any form of a representative or class proceeding. The arbitral tribunal has no power to consider the enforceability of this class arbitration waiver and any challenge to the class arbitration waiver may only be raised in a court of competent jurisdiction. If any provision of this arbitration agreement is found unenforceable, the unenforceable provision will be severed and the remaining arbitration terms will be enforced.

20. NOTICES.

- a To You. We may provide any notice to you under these Terms by: (i) sending a message to the e-mail address you provide or (ii) letter mailed to the shipping address you provide. Notices sent by e-mail will be effective when we send the e-mail and notices we provide by posting will be effective upon posting. It is your responsibility to keep your e-mail address current.
- b To Us. To give us notice under these Terms, you must contact us as follows: (i) by e-mail to info@litezilla.com or (ii) by personal delivery, overnight courier or registered or certified mail to: LiteZilla LLC, 4997B North 33rd Street, Milwaukee, WI 53209. We may update the e-mail address or physical address for notices to us by posting a notice on the Site. Notices provided by personal delivery will be effective immediately. Notices provided by facsimile transmission or overnight courier will be effective one business day after they are sent. Notices provided by registered or certified mail will be effective three business days after they are sent.

21. SEVERABILITY.

If any term or provision of this Agreement is invalid, illegal or unenforceable in any jurisdiction, such invalidity, illegality or unenforceability shall not affect any other term or provision of this Agreement or invalidate or render unenforceable such term or provision in any other jurisdiction.

22. SURVIVAL.

Provisions of these Terms which by their nature should apply beyond their terms will remain in force after any termination or expiration of this Agreement including, but not limited to, the following provisions: Insurance, Compliance with Laws, Confidential Information, Governing Law, Submission to Jurisdiction and Survival.

LIFETIME TECHNICAL SUPPORT

If you need extra help with the installation, we are happy to schedule a video chat and walk you through the whole process.

Our knowledgeable staff of Illumineers is here to serve you.

Email: Adam@LiteZilla.com

Phone/Text: 414-477-7772